



Extra robust, pressure-, saltwater- and corrosion-proof sensor housing as an alternative for the SB.. housings for especially harsh operating conditions, aggressive fluids and saltwater

Features

- extra robust, pressure-, saltwater- and corrosion-proof stainless steel housing
- twist free 4-point fastening of rigid 3.2mm thick base PCB
- all sensors installed as in SB1I, SB2I, SB1S, SB1U, SB360, SBS1U
- all SEIKA sensors fit the housing and can be installed in different directions of operation
- sensors and sensor electronics electrically isolated from housing

Description

The XB.. is an extra robust, pressure-, saltwater- and corrosion-proof stainless steel housing with an integrated sensor or sensors and one of the sensor electronic systems described for the SB.. sensor casings.

The compact PG stainless steel cable gland and stainless steel housing size enable the use of this high quality measuring system in especially harsh operating conditions.

Application

The XB.. is suited for taking precise inclination or acceleration measurements under harsh circumstances and returning of a 0...5V or 4...20mA output signal. Areas of successful implementation include construction, mining, agricultural machinery, transportation and conveyor systems, ships, in aggressive fluids and in saltwater, in high pressure environments, operation and automation technology as well as general mechanical engineering.

Technical Specifications

Housing material	V4A (saltwater proof)
Cable fixing	PG9 cable gland, clamping range 8mm ... 10.5mm
Compressive strength	10 bar (1Mpa), 100m WS
Terminals	Depending on the built-in board
Measuring range, Resolution, etc.	dependent on implemented sensor
Mounting position	Any

Measuring planes (N.. sensor)	3 main housing planes
Measuring plane (NG.. sensor)	parallel to housing bottom
Measuring directions (B.., BD.. sensor)	in X,Y,Z coordinates of housing
Electrical values	according to installations in the according SB.. housing
Operating temperature	-40°C ... +85°C

Options: custom measuring ranges, calibration protocol, silicon encapsulation, custom wiring

XB1I with NG inclinometer - Dimensions and Measuring Directions

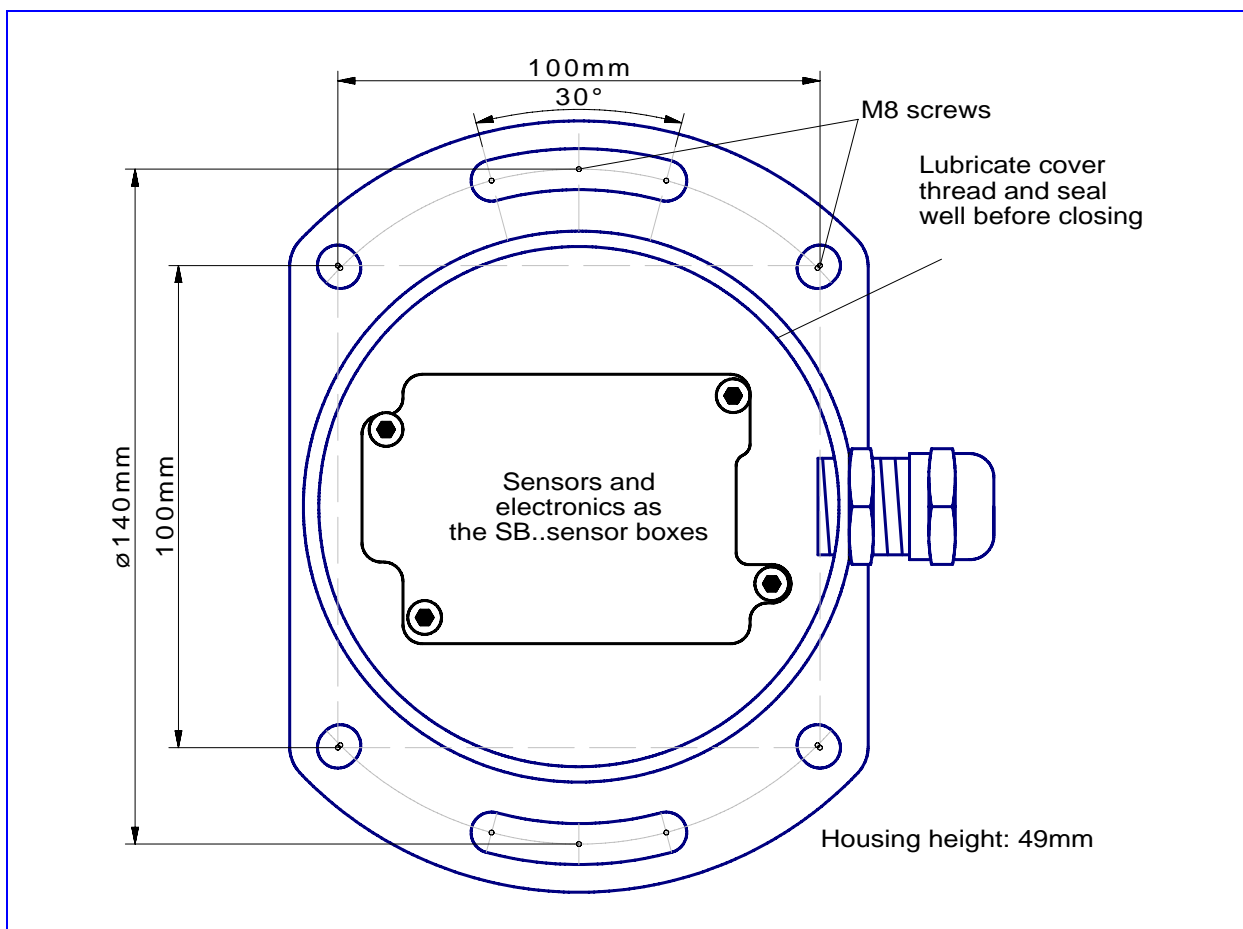

XB.. with underwater connector

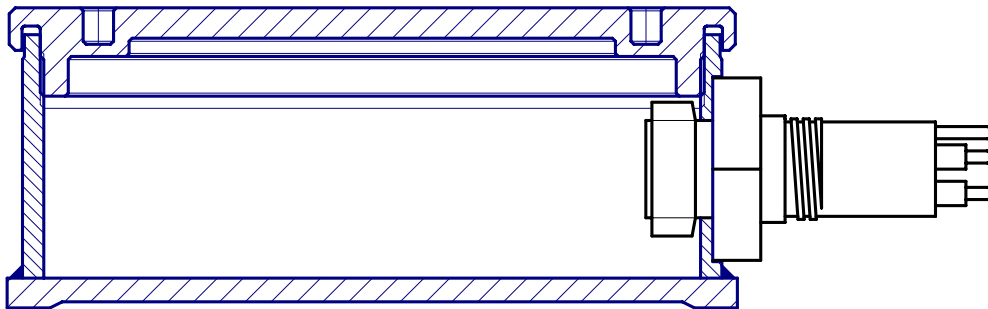

Material: V4A

Connector:

Subconn Metal Shell
1500 Series 4 Contacts
Typ: BCR1504M

for Cableconnector:
MCIL4F or MCDC4F
plus MCDLSF

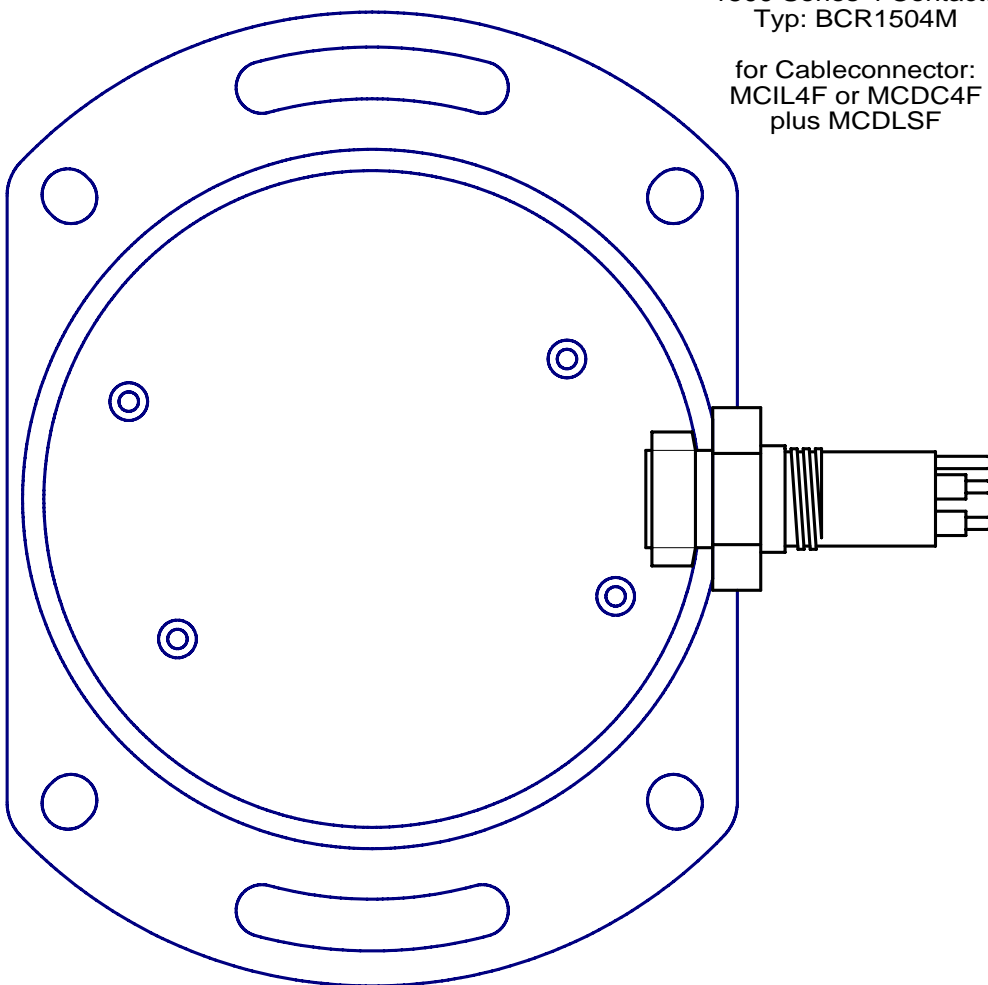

Please order connector plug (no. MCIL4F or MCDC4F), coupling ring (no. MCDLSF) and cable from your nearest Subconn distributor (not supplied).